

WAFER STYLE KNIFE GATE VALVE

The EK model knife gate is an uni-directional wafer valve designed for general industrial service applications. The design of the body and seat assures non clogging shut off on suspended solids in industries such as:

- Pulp and Paper
- Wastewater treatment plants
- Food and Beverage
- Mining
- Power plants
- Chemical plants
- Bulk handling
- etc.

Sizes: DN 50 to DN 1200 (larger diameters on request)

Working pressure:

DN 50 to DN 125	16 bar
DN 150 to DN 250	10 bar
DN 300 to DN 400	6 bar
DN 450	5 bar ⁽¹⁾
DN 500 to DN 600	4 bar ⁽¹⁾
DN 700 to DN 1200	2 bar

(1) 6 bar with duplex gate

Standard flange connection:

EN 1092 PN 10
 Other flange connections available on request
 ASME B16.5 (class 150) EN 1092 PN 6 EN 1092 PN 16
 EN 1092 PN 25 BS "D" and "E"

Directives: For EU Directives and other Certificates, please see the document: Directives and Certificates Compliance - Knife Gate Valves - Catalogues and Datasheets



All valves are tested prior to shipping in accordance with the standard developed by the Quality Control Department at ORBINOX.

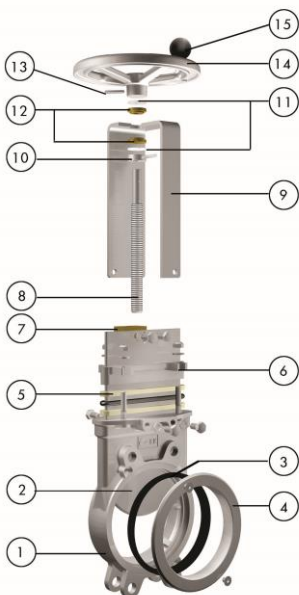

STANDARD PARTS LIST

Part:	Stainless Steel:
1- Body	CF8M (1.4408)
2- Gate	AISI 316 (1.4401)
3- Seat	EPDM
4- "K" Ring	CF8M (1.4408)
5- Packing	Dynapack (Graphite impregnated PTFE and Aramid yarn combination with an elastomeric core)+ (EPDM O-ring)
6- Gland Follower	CF8M (1.4408)
7- Stem nut	Brass
8- Stem	Stainless Steel
9- Yoke	AISI 304 (1.4301)
10- Axial fixing bush	AISI 304 (1.4301)
11- Friction washer	PET + solid lubricant
12- Bushing	Bronze
13- Spring Pin	AISI 420 (1.4021) (ISO 8752)
14- Handwheel	Ø≤310: Aluminium (AlSi12); Ø≥410 GJS400 (GGG40)
15- Knob	Black bakelite

DESIGN FEATURES

BODY:

Wafer style cast stainless steel monoblock with raised face, with reinforced ribs in larger diameters for extra body strength. Internal cast-in gate wedges and guides allows for tighter shut-off.

Full port design for greater flow capacity and minimal pressure drop. Internal design avoids any build up of solids that would prevent valve from closing.

GATE:

Stainless steel gate. Gate is polished on both sides to avoid jamming and seat damage. Bottom of the gate edge is machined to a bevel to cut through solids for a tighter seal in the closed position. The thickness and/or material of the gate can be changed on request for higher pressure requirements.

SEAT: (resilient)

Unique design that mechanically locks the seal in the internal of the valve body with a cast, easy to replace, stainless steel seat ring. Standard EPDM also available in different materials such as PTFE, etc.(Fig.1)

PACKING:

Long-life packing with several graphite impregnated PTFE / Aramid yarn combination with an elastomeric core, plus an EPDM O-ring, with an easy access packing gland ensuring a tight seal.

Long-life packing is available in a wide range of materials.

STEM:

The standard stainless steel stem offers a long corrosion resistant life. Standard configuration is non-rising stem. For those pneumatic actuated valves, stem linkage is provided by means of a stainless steel coupling and a pin (Fig. 2).

ACTUATORS:

All actuators supplied by ORBINOX are interchangeable, and supplied with an standard mounting kit for installation purposes on site.

YOKE or ACTUATOR SUPPORT:

Made of stainless steel (EPOXY coated steel available on request). Compact design makes it extremely robust even under the most severe conditions.

EPOXY COATING:

The epoxy coating on all ORBINOX cast iron and carbon steel components is electrostatically applied making the valves corrosion-resistant with a high quality finished surface. The ORBINOX standard colour is RAL-5015 blue.

GATE SAFETY PROTECTION:

ORBINOX automated valves are provided with gate guards in accordance with EU Safety Standards. The design feature prevents any objects from being caught accidentally while the gate is moving.



Fig.1



Fig.2

OTHER OPTIONS

Gate guards for actuators with proximity switches:

It has been made a special design which allows horizontal and parallel mounting of the proximity switches including protection to them.

Bonnet (Fig.1):

Assures tight sealing to atmosphere for using with hazardous gas or fluids.

Reduces packing maintenance.

Flush ports:

Allow for cleaning of solids trapped within the body cavities that can obstruct the flow or prevent the valve from closing. Depending on the process, purging can be made with air, steam, liquids, etc.

Other materials of construction:

Special alloys such as AISI 317 (1.4449), 254SMO (1.4547), Hastelloys, etc.

Fabricated valves:

ORBINOX designs, produces and delivers special fabricated valves for special process conditions (big sizes and/or high pressures).

V-port (Fig.2):

60 degree and pentagonal port design. Selection depends on the desired fluid control type.

Double packing:

Alternative solution to bonnet



Fig.1



Fig.2

SURFACE TREATMENTS

Valve components can be protected or coated for a longer life expectancy, depending on the application of the valves and the valve service conditions.

At ORBINOX we can offer alternative treatments and coatings for the different valve components to improve their properties against abrasion (Stellite, polyurethane...), against corrosion (Halar, Rilsan, galvanizing...) and against adherence (polishing, PTFE...).

We recommend to contact our technical department.

ACTUATOR TYPES

MANUAL:

- Handwheel (rising stem)
- Handwheel (non-rising stem)
- Chainwheel
- Lever
- Bevel Gear
- Other (square nut)

AUTOMATIC:

- Electric (rising & non-rising stem)
- Pneumatic (single & double-acting)
- Hydraulic



All actuators supplied by ORBINOX are interchangeable.



Standard Handwheel (Non Rising Stem)



Electric



Pneumatic



Chainwheel



Handwheel (Rising Stem)



Single-acting cylinder



Bevel Gear



Lever

ACCESSORIES:

- Mechanical Stops
- Actuator manual override
- Positioners
- Proximity Switches
- Stem extensions

- Gate block (Fig.1)
- Solenoid valves
- Limit Switches
- Floor stands

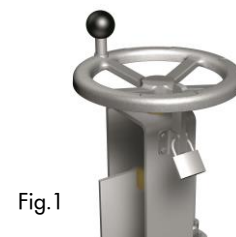

Fig.1

Please consult our technical department.

TEMPERATURE CHART

SEAT / SEALS

Material	Max.T (°C)	Applications
EPDM (E)	120	Acids and non mineral oils.
NBR (N)	120	Resistance to petroleum products.
FKM-FPM (V)	200	Chemical service / High temp.
VMQ (S)	250	Food service / High temp.
PTFE (T)	250	Corrosion resistance
Polyurethane	90	Abrasion resistance

PACKING

Material	Max.T (°C)	pH
Dynapack (DP)	270	2-14
Braided PTFE (TH)	260	0-14
Graphited (GR)	600	0-14
Ceramic fibre (FC)	1200	--

NOTE: all types include an elastomere O-ring (same material as seal), excluding TH, GR and FC.

More details and other materials under request.

SEAT TYPES

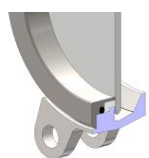

METAL/METAL

For applications with:

- High temperature
- High density media application
- When full tightness is not required

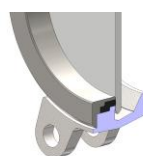

TYPE "K" SEAT (EPDM)

- Standard replaceable resilient EPDM seat
- Replaceable stainless steel ring

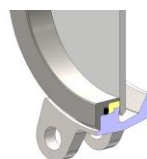

TYPE "K" SEAT (PTFE)

- Replaceable resilient PTFE + O-ring seat
- Replaceable stainless steel ring

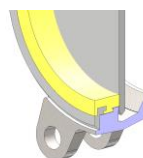

POLYURETHANE

- Replaceable polyurethane seat ring

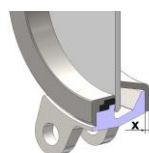

DEFLECTION CONE "C"

- Deflects the media away from any valve internal exposed parts (gate guides, seat, .)
- Material: AISI 316 (1.4401), CA15, Ni-Hard, etc.
- Face-to-face dimension increases:
 - DN 50 to DN 250 X = 9mm
 - DN 300 to DN 600 X = 12mm
 - Larger diameters on request

HANDWHEEL (non- rising stem)

- Standard handwheel actuator
 - DN 50-300: Aluminium handwheel
 - DN ≥ 350: GJS400 handwheel
- Recommended for installation where space is limited
- Consists of:
 - Handwheel with knob
 - Stem
 - Yoke bushing
 - Stem nut fixed to the gate
- Available from DN 50 to DN 1000
- Options:
 - Locking Device
 - Extension
 - Square Nut Drive
- Gear is recommended above DN350

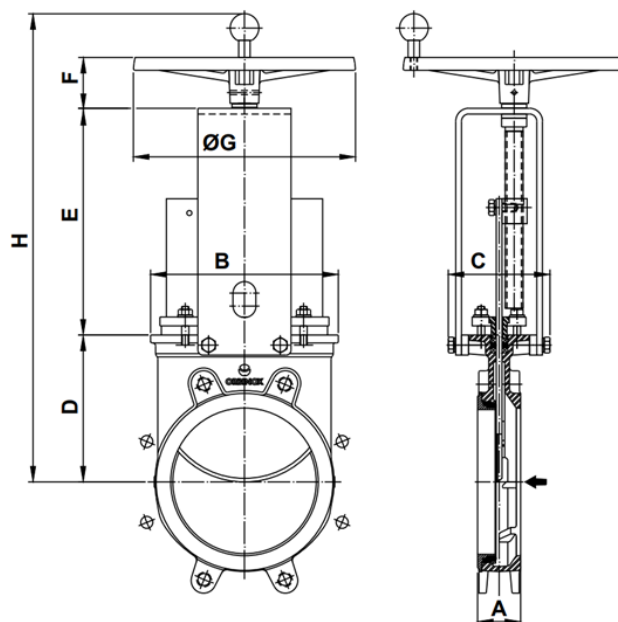

DN	A	B	C	D	E	F	ØG	H	Weight (kg.)
50	41	119	125	105	144	63	225	373	7
65	41	134	125	115	161	63	225	400	8
80	51	149	125	124	177	63	225	425	9
100	51	169	125	140	202	63	225	466	11
125	56	180	125	150	226	63	225	500	15
150	60	206	125	175	252	63	225	551	20
200	60	262	142	205	317	73	310	656	32
250	69	318	142	250	372	73	310	756	46
300	78	372	142	300	422	73	310	856	62
350	78	431	197	338	516	98	410	1013	96
400	89	486	197	392	572	98	410	1123	124
450	89	540	201	432	635	98	550	1226	168
500	114	602	201	485	698	98	550	1342	192
600	114	708	201	590	797	98	550	1546	245
700	118	834	380	686	890	150	800	1723	405
750	118	884	380	760	945	150	800	1855	455
800	118	1015	320	795	989	150	800	1934	512
900	118	1040	320	900	1118	150	800	2168	630
1000	118	1150	320	980	1220	150	800	2350	732

GEAR

- Recommended for valves larger than DN 350 and working pressures greater than 3.5 bar
- Consists of:
 - Stem
 - Stem protector
 - Bevel Gear Actuator with Handwheel (Standard Ratio 4:1)
- Available from DN 200 to DN 1200
- Options:
 - Locking device
 - Extension
 - Chainwheel

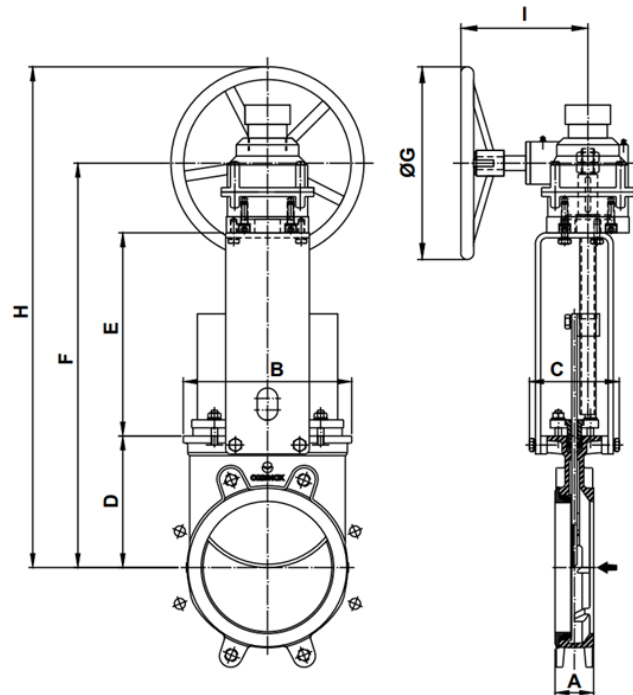

DN	A	B	C	D	E	F	ØG	H	I
200	60	262	142	205	305	585	300	735	200
250	69	318	142	250	360	685	300	835	200
300	78	372	142	300	410	790	300	940	200
350	78	431	197	338	487	872	450	1097	262
400	89	486	197	392	540	1044	450	1269	262
450	89	540	201	432	589	1068	450	1293	262
500	114	602	201	485	652	1249	450	1474	262
600	114	708	201	590	754	1419	450	1644	262
700	118	834	380	683	900	1693	450	1918	262
750	118	884	380	760	945	1752	450	1977	262
800	118	1015	320	791	968	1886	650	2111	260
900	118	1040	320	895	1118	2157	650	2482	288
1000	118	1150	320	975	1225	2350	650	2675	288
1200	150	1400	450	1230	485	3025	850	3450	455

PNEUMATIC CYLINDER

- The standard pneumatic actuator (double acting on-off cylinder) consists on:
 - $\varnothing \leq 300$: Aluminum barrels
 - $\varnothing \geq 350$: Composite barrels
 - Aluminum covers
 - Stainless steel (AISI 304) piston rod
 - Nitrile coated steel piston
- Available from DN 50 to DN 1000
- Actuator sized for 6 bar air supply
- For valves installed in a horizontal position, we recommend U-type support plates and/or actuator support.
- Options:
 - Gate guards for proximity switches
 - Hard anodized barrel and covers
 - Stainless steel barrel and covers
 - Over/Undersized cylinder
 - Manual override
 - Fail safe system
 - Limit switches
- Instrumentation (on request):
 - Positioners
 - Solenoid valves
 - Flow regulators
 - Air preparation units

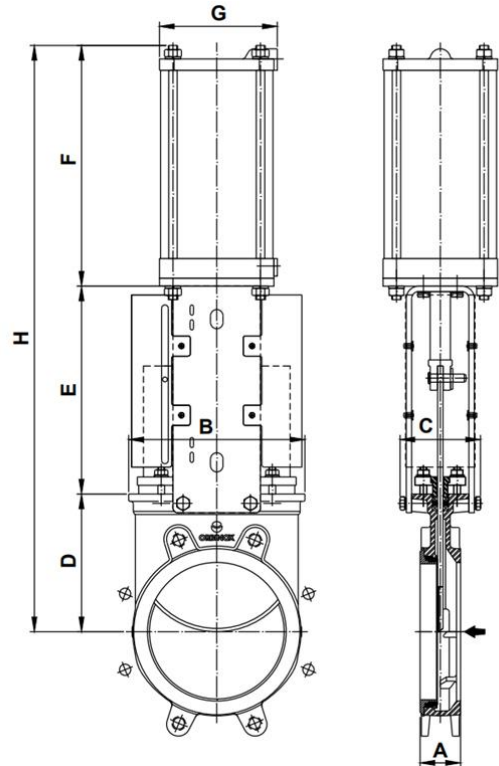

DN	A	B	C	D	E	F	G	H	Weight (kg.)	Standard Cyl.	Connect.
50	41	119	125	105	129	178	115	412	9	C100/62	1/4" G
65	41	134	125	115	146	193	115	454	10	C100/77	1/4" G
80	51	149	125	124	162	211	115	497	11	C100/95	1/4" G
100	51	169	125	140	187	231	115	558	14	C100/115	1/4" G
125	56	180	125	150	211	271	140	632	20	C125/143	1/4" G
150	60	206	125	175	237	296	140	708	27	C125/168	1/4" G
200	60	262	142	205	309	358	175	872	46	C160/220	1/4" G
250	69	318	142	250	364	428	220	1042	69	C200/270	3/8" G
300	78	372	142	300	414	478	220	1192	86	C200/320	3/8" G
350	78	431	197	338	500	541	220	1379	135	C200/375	3/8" G
400	89	486	197	392	577	599	277	1568	165	C250/425	3/8" G
450	89	540	270	432	643	641	277	1715	220	C250/475	3/8" G
500	114	602	270	485	706	691	277	1882	280	C250/525	3/8" G
600	114	708	270	590	805	791	277	2196	330	C250/625	3/8" G
700	118	834	380	686	875	985	277	2571	520	C250/730	3/8" G
750	118	884	380	760	930	1035	382	2740	585	C300/780	1/2" G
800	118	1015	320	791	974	1085	382	2844	650	C300/830	1/2" G
900	118	1040	320	895	1105	1202	382	3220	850	C300/930	1/2" G
1000	118	1146	320	975	1217	1296	382	3496	1060	C300/1030	1/2" G

FAIL SAFE SYSTEM

SINGLE ACTING (SPRING RETURN)

- This actuator (single acting cylinder) consists of:
 - Aluminum barrel and covers
 - Steel spring
 - Stainless Steel (AISI 304) piston rod
 - Nitrile coated steel piston
- Available from DN 50 to DN 300
- Supply pressure: min. 5 bar - max. 10 bar
- Options:
 - Fail open
 - Fail close

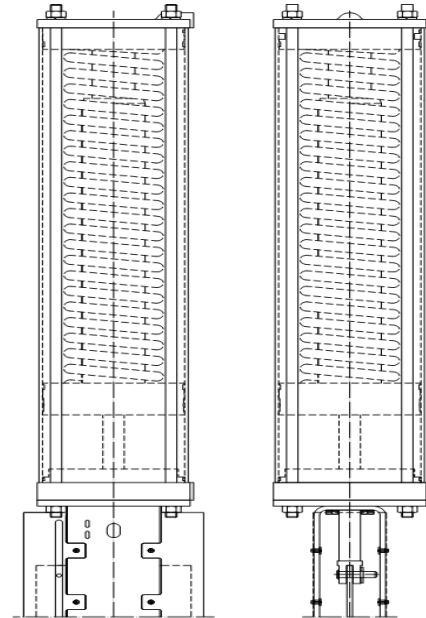
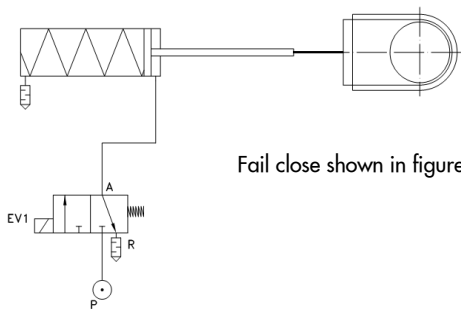

DOUBLE ACTING WITH AIR TANK

- Fail safe systems consists of: double acting pneumatic cylinder, air tank and all the necessary elements according to the available options (solenoid valve, spool valve,...)
- Different solution available (pressure switches,...)
- Available for all diameters
- Supply Pressure: min. 3.5 bar - max. 10 bar

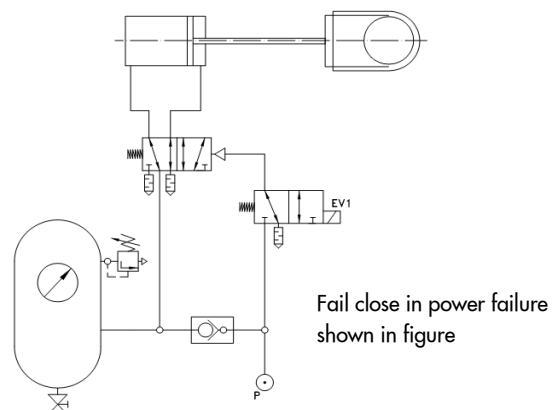
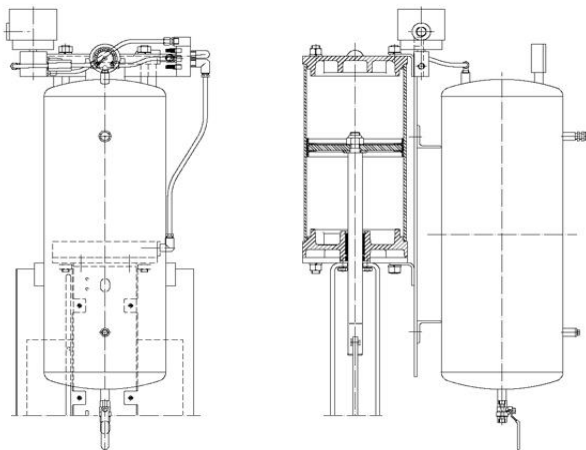

ELECTRIC ACTUATOR (non- rising stem)

- Consists of:
 - Electric actuator
 - Motor support yoke flange acc. to ISO 5210 / DIN 3338

- The standard electric motor is equipped with:
 - Manual emergency operation
 - Limit switches (open/closed)
 - Torque switches

- Available from DN 50 to DN 1200

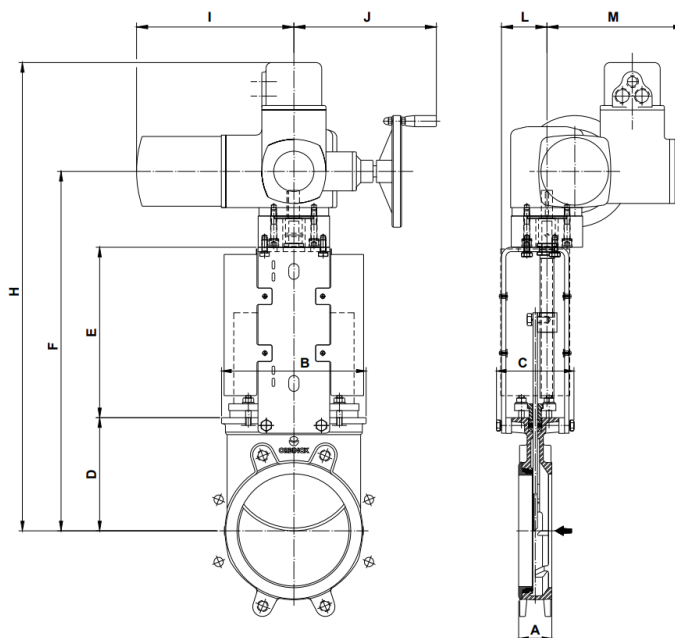

- Wide range of types and marks available to meet customer's needs.



DN	A	B	C	D	E	F	ØG	H	I	J	L	M	Stem Ø x pitch	Torque (Nm)
50	41	119	125	105	129	377	160	552	265	249	72	238	20 x 3	10
65	41	134	125	115	146	404	160	579	265	249	72	238	20 x 3	10
80	51	149	125	124	162	429	160	604	265	249	72	238	20 x 3	10
100	51	169	125	140	187	470	160	645	265	249	72	238	20 x 3	10
125	56	180	125	150	211	504	160	679	265	249	72	238	20 x 3	15
150	60	206	125	175	237	560	160	730	265	249	72	238	20 x 3	20
200	60	262	142	205	309	669	160	814	265	249	82	238	25 x 4	30
250	69	318	142	250	364	799	160	944	265	249	82	238	25 x 4	45
300	78	372	142	300	414	904	160	1044	265	249	82	238	25 x 4	40
350	78	431	197	338	472	940	200	1115	283	254	128	248	35 x 6	70
400	89	486	197	392	552	1044	200	1219	283	254	128	248	35 x 6	90
450	89	540	270	432	610	1172	200	1347	283	254	130	248	35 x 6	110
500	114	602	270	485	670	1280	200	1455	283	254	130	248	35 x 6	95
600	114	708	270	590	800	1565	315	1750	389	336	130	286	35 x 6	140
700	118	834	380	686	900	1763	315	1948	389	336	202	285	40 x 7	120
750	118	884	380	760	945	1882	315	2067	389	336	202	286	40 x 7	140
800	118	1015	320	791	980	1948	315	2133	389	336	202	286	50 x 8	180
900	118	1040	320	895	1087	2157	400	2342	389	339	202	286	50 x 8	220
1000	118	1150	320	975	1200	2350	400	2535	389	339	202	286	50 x 8	300
1200	150	1400	450	1037	1485	2732	500	2917	430	365	284	303	60 x 9	480

FLANGE AND BOLTING DETAILS

EN 1092 PN10

DN	K	n°	M	T	  
50	125	4	M-16	11	2 - 2 - 0
65*	145	4	M-16	11	2 - 2 - 0
80	160	8	M-16	11	2 - 2 - 4
100	180	8	M-16	11	2 - 2 - 4
125	210	8	M-16	11	2 - 2 - 4
150	240	8	M-20	14	2 - 2 - 4
200	295	8	M-20	14	2 - 2 - 4
250	350	12	M-20	18	4 - 2 - 6
300	400	12	M-20	18	4 - 2 - 6
350	460	16	M-20	18	6 - 4 - 6
400	515	16	M-24	20	6 - 4 - 6
450	565	20	M-24	20	8 - 6 - 6
500	620	20	M-24	24	8 - 6 - 6
600	725	20	M-27	24	8 - 6 - 6
700	840	24	M-27	20	10 - 6 - 8
800	950	24	M-30	20	10 - 6 - 8
900	1050	28	M-30	20	12 - 8 - 8
1000	1160	28	M-33	20	12 - 8 - 8
1200	1380	32	M-36	30	22 - 6 - 4

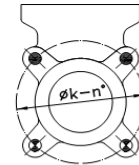

DN 50-65

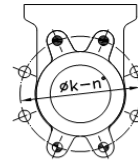

DN 80-200

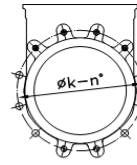

DN 250-300

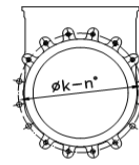

DN 350-400

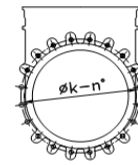

DN 450-600

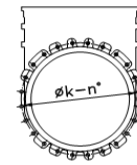

DN 700-800

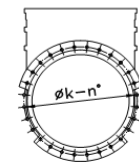



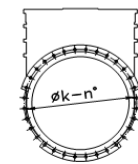

DN 900-1000



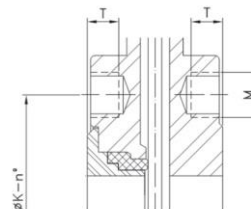

DN 1200

* Flange drilling of DN-65 PN10/16 according to EN1092 allow 4 or 8 drills. ORBINOX designs of DN-65 PN10/16 have 4 drills



-  BLIND TAPPED HOLES
-  TAPPED THROUGH
-  THROUGH HOLED

ASME B16.5, class 150

DN	K	n°	M	T	  
2"	4 3/4"	4	5/8" - 11 UNC	1/2"	2 - 2 - 0
2 1/2"	5 1/2"	4	5/8" - 11 UNC	1/2"	2 - 2 - 0
3"	6"	4	5/8" - 11 UNC	1/2"	2 - 2 - 0
4"	7 1/2"	8	5/8" - 11 UNC	1/2"	2 - 2 - 4
5"	8 1/2"	8	3/4" - 10 UNC	1/2"	2 - 2 - 4
6"	9 1/2"	8	3/4" - 10 UNC	1/2"	2 - 2 - 4
8"	11 3/4"	8	3/4" - 10 UNC	1/2"	2 - 2 - 4
10"	14 1/4"	12	7/8" - 9 UNC	18/32"	4 - 2 - 6
12"	17"	12	7/8" - 9 UNC	18/32"	4 - 2 - 6
14"	18 3/4"	12	1" - 8 UNC	7/8"	4 - 4 - 4
16"	21 1/4"	16	1" - 8 UNC	3/4"	6 - 4 - 6
18"	22 3/4"	16	1 1/8" - 7 UNC	3/4"	6 - 4 - 6
20"	25"	20	1 1/8" - 7 UNC	1/2"	8 - 6 - 6
24"	29 1/2"	20	1 1/4" - 7 UNC	1/2"	8 - 6 - 6

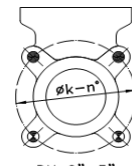

DN 2"-3"

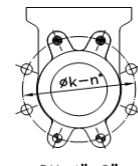

DN 4"-8"

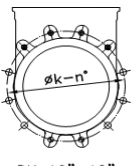

DN 10"-12"

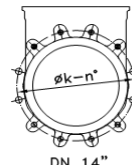

DN 14"

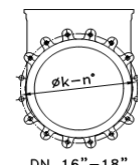

DN 16"-18"

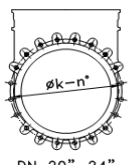

DN 20"-24"